

Question block created by wizard

This exam contains 72 questions.

1. The properties of alloy steel can be altered by....
 - a. UV light.
 - b. some element (other than carbon), or jointly with carbon.
 - c. carbon.

2. Many different metals are required in the repair of aircraft.
This is a result of the varying needs with respect to....
 - a. strength, weight, durability and cost.
 - b. strength, weight, durability and resistance to deterioration.
 - c. colour of metal and the heat strength.

3. When steel is cold - worked, hammered, bent, rolled, stresses and strain are set up and its crystal structure is disturbed.
The metal becomes....
 - a. flexible and strong.
 - b. harder, stiffer and stronger.
 - c. soft.

4. To overcome the deficiencies of plain-carbon steels....
 - a. alloy steels have been developed.
 - b. sand blasting was included in their development.
 - c. alu alloys were developed.

5. Rotating fatigue test machines vary in design, but are generally based around the....
 - a. Macqueen principle.
 - b. Scleroscope principle.
 - c. Wohler principle.

6. If a material is subjected to repeated or cyclic stress it should be tested for....
 - a. hardness.
 - b. fatigue strength.
 - c. softness.

7. What is the position of the specimen during an Izod impact test?
- Horizontal
 - Both are possible.
 - Vertical.
8. Bauxite is crushed and treated with caustic soda solution to produce....
- aluminium and nickel.
 - aluminium combined with cadmium and water.
 - aluminium oxide combined with water.
9. Which metal is a very light metal, being about $\frac{2}{3}$ of the weight of aluminium?
- Copper.
 - Bronze.
 - Magnesium.
10. The ability of a material to resist elastic deformation when subjected to stress is described as....
- rigidity.
 - hardness.
 - tongue and groove.

11. What does the second digit of the material-code of non-ferro materials indicate?

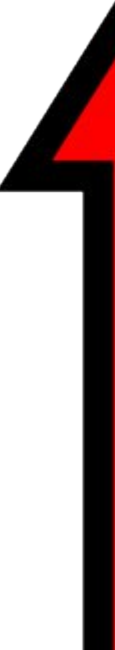
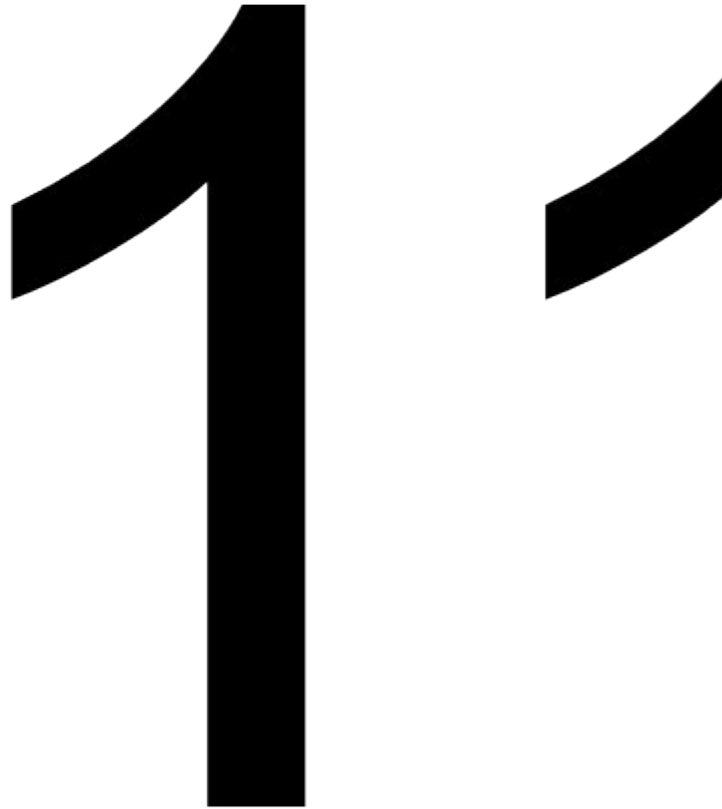

- a. Solid material
- b. % Basic alloy element.
- c. The number of modifications.

12. When adding zinc as alloying elements to aluminium. What is the group of aluminium alloys?

- a. 7xxx alloys.
- b. 5xxx alloys.
- c. 6xxx alloys.

13. In a tension strain diagram for steel we have a yield stress point.

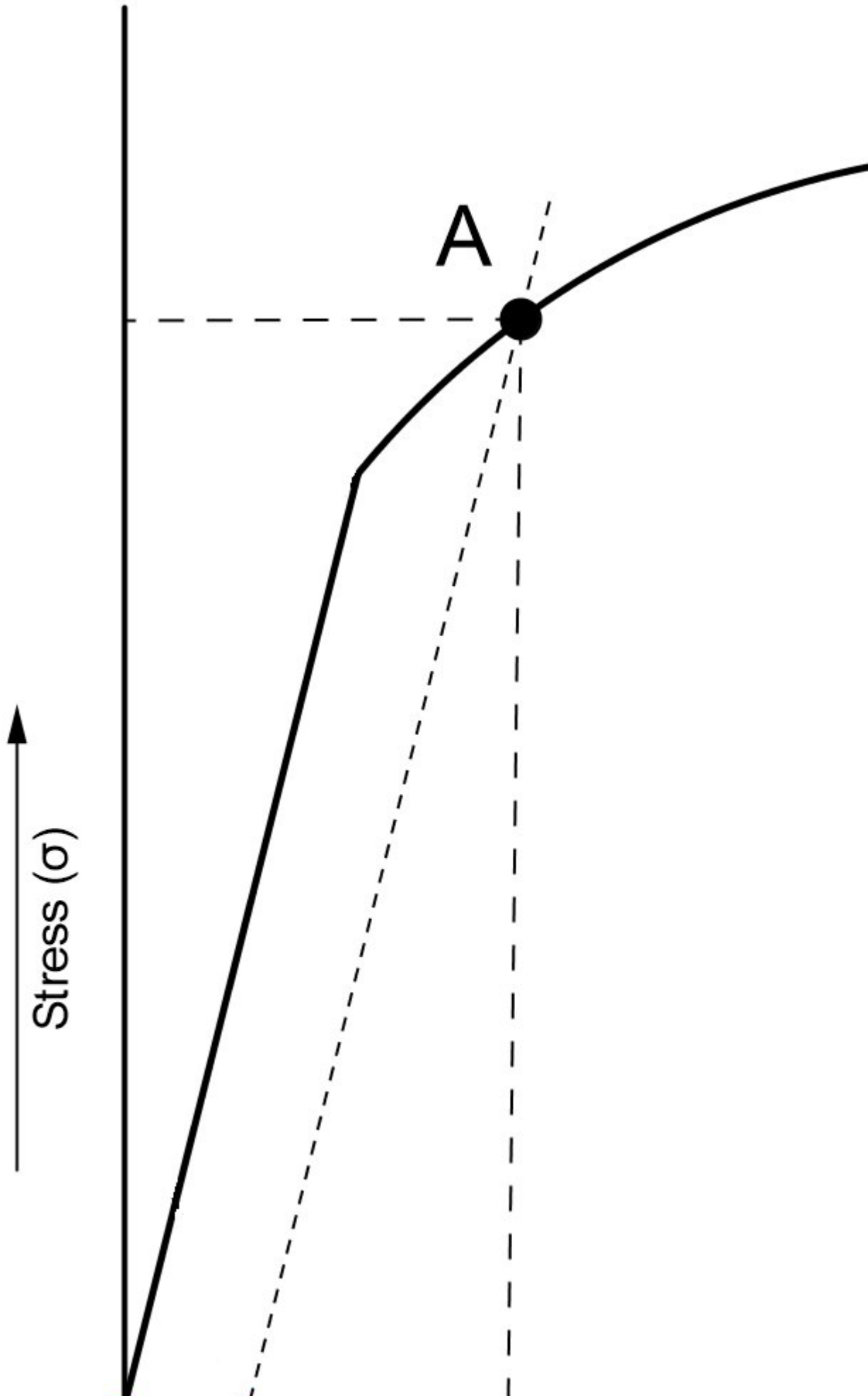

What is the name of this point at a non-ferro metal?

- a. Ultimate stress point.
- b. Offset yield point.
- c. Elasticity point.

14. What is an advantage of Carbon Fibre Reinforced products?

- a. It is very easy to shape or mould.
- b. Considerable weight savings over conventional materials.
- c. Can be used at very high temperatures.

15. Carbon fibre....

- a. has a higher impact resistance than aluminium.
- b. both answers are correct.
- c. is lighter and stiffer than fibre glass.

16. Why do we use sealant?

- a. To prevent crevice or contact corrosion.
- b. To stick parts together.
- c. As a ground layer for paint.

17. What kind of stress do adhesive joints experience?

- a. Pressure.
- b. Peel.
- c. Compressive strain.

18. Ideally, composite components should be fully identified before a repair is performed.

Where can the aircraft technician find the data of ply orientation, core ribbon direction etc.?

- a. Structural repair manual.
- b. Aircraft maintenance manual.
- c. Parts catalogue inventory.

- 19.** After paint removal, additional damage assessment is performed, because the hidden damage now becomes more apparent.
- What must be done?
- All damaged material must be removed and repaired in accordance with SRM.
 - A tap test has to be performed.
 - Internal damage is allowed but limited to 20 percent.
- 20.** What is a property of hard wood?
- High density and the wood is coarser.
 - Low density and wood fibres are thin-walled.
 - High density and wood fibres are thick.
- 21.** Testing a wood glue connection, when is the glue connection acceptable?
- The glue connection is not getting thinner during the test.
 - The wood fibres will break and not the glue line.
 - If it holds for 30 minutes.
- 22.** Inspection access is provided to every control bell cranks, drag-wire junction, cable guide, pulley, wing fitting. These access points are referred to as....
- metal stress plates.
 - fabric windows.
 - inspection rings.
- 23.** Fabric openings that cannot be repaired by closing with stitches may be repaired....
- with a new fabric section.
 - by replacement of the complete skin fabric surface.
 - with a wooden insert.
- 24.** The effect on corrosion by increasing the temperature is....
- a decrease in the rate of oxidation of a metal.
 - an increase in the rate of oxidation of a metal.
 - a stabilization of oxidation of a metal.
- 25.** Stress corrosion cracking is a process caused by....
- the combined action of a sustained tensile stress and a corrosive environment.
 - low applied service loads.

c. a corrosive environment.

26. This type of corrosion can occur where steel bolts and nuts are in contact with aluminium alloys such as aircraft wheels.

What is the name of this corrosion type?

- a. Dissimilar metal corrosion.
- b. Inter-granular corrosion.
- c. Surface corrosion.

27. What corrosion is the result of rubbing movement between two heavily loaded surfaces?

- a. Dissimilar metal corrosion.
- b. Inter-granular corrosion.
- c. Fretting corrosion.

28. Which will affect the rate of corrosion the most?

- a. Moisture loaded atmosphere.
- b. High altitude and cold.
- c. Dry, high temperature environment.

29. Factors affecting corrosion. The worst conditions would exist in a....

- a. dry and cool environment.
- b. hot and wet environment.
- c. quick changes in temperature and dry environment.

30. What material is highly corrosion-resistant but should be insulated from other metals?

- a. Iron.
- b. Titanium.
- c. Copper.

31. The most common corrosion on steel is recognisable by....

- a. corrosion products are white and voluminous.
- b. general etching of the surface and a black deposit.
- c. red rust of iron.

32. American national fine is abbreviated as....

- a. UNF
- b. ANF
- c. USNF

33. A standard hexagonal nut with a plastic insert is....



- a. a nyloc nut.
- b. a term used to describe a lock nut which has a prevailing torque.
- c. a fastener snap nut.

34. For gauging external threads a 'go' gauge will be used to check the....

- a. minimum diameter of the thread.
- b. maximum minor diameter of the thread.
- c. maximum diameter of the thread.

- 35.** The nominal diameter of a thread is the....
- a. diameter equal to the external diameter of the threads.
 - b. diameter equal to the internal diameter of the threads.
 - c. minor diameter.

- 36.** DD in a material identification means....

- a. aluminium alloy.
- b. diameter.
- c. double drilled.

- 37.** AN bolts can have one of the following head styles....

- a. hexagon head, clevis or eyebolt.
- b. hook and plane.
- c. trapezium and triangle.

- 38.** A fillister head screw has....

- a. no lock wire drill holes.
- b. self-locking slots.
- c. wire lock drill holes.

- 39.** A stud should be fitted with a....

- a. stud box.
- b. drill box.
- c. torque box.

- 40.** Taper pins are usually made of....



- a. aluminium alloy.
- b. high-tensile steel.
- c. cadmium-plated steel.

41. Cotter pin legs can be spread in....

- a. two methods
- b. one method
- c. three methods

42. Shake proof washers....

- a. can be re-used if they have retained their spring tension.
- b. should be used only ones.
- c. can be re-used

43. Which locking method is correct?

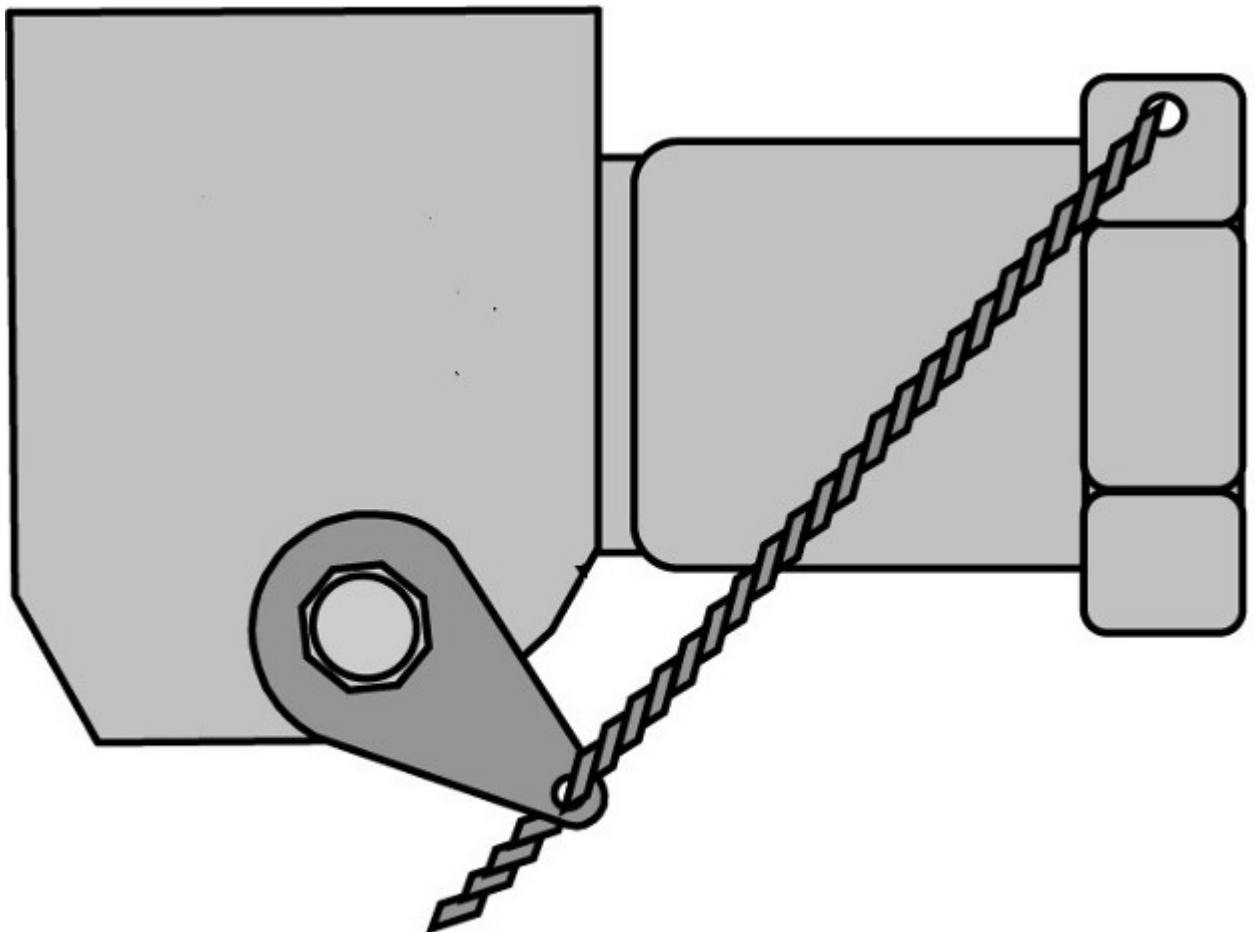

- a.

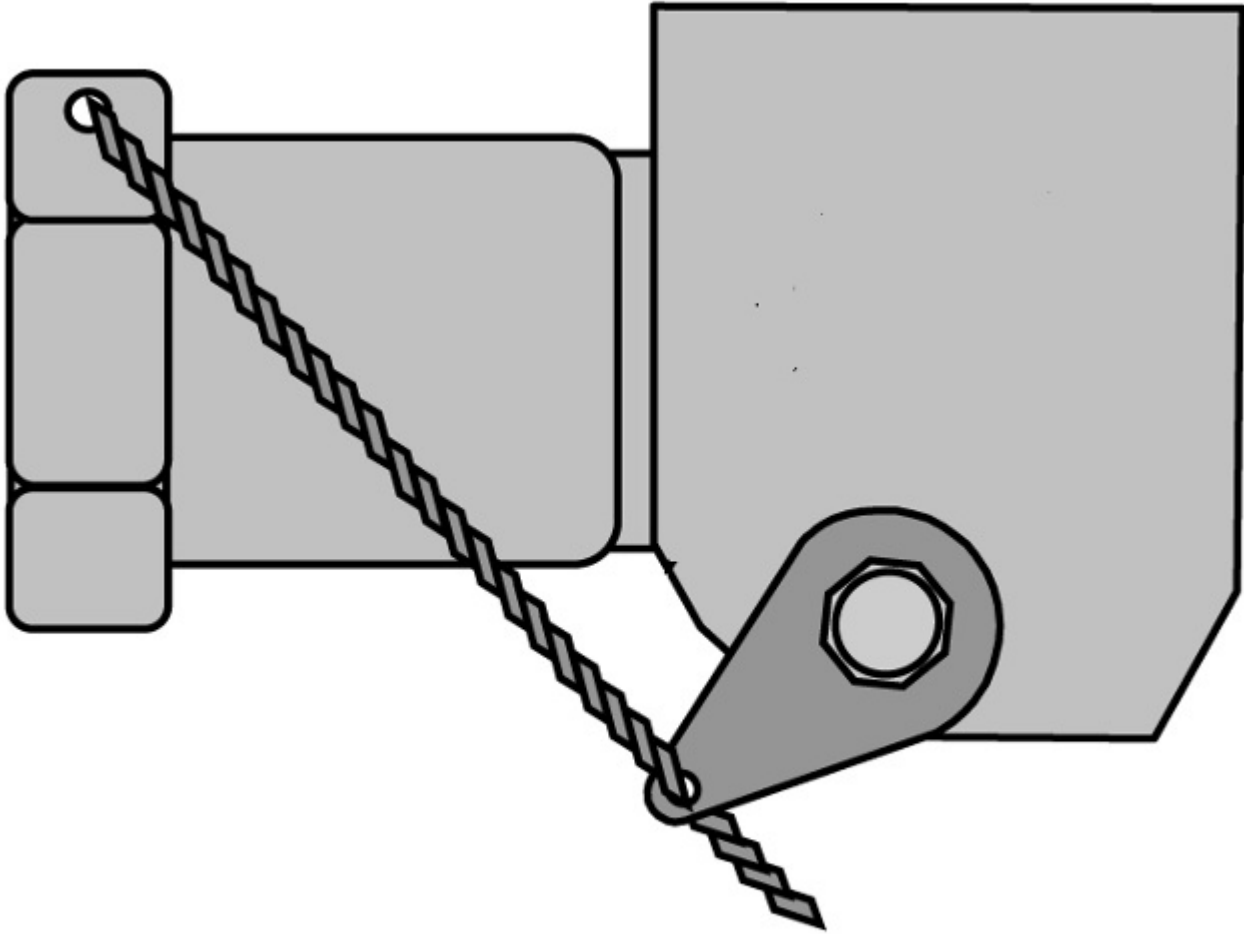

b.

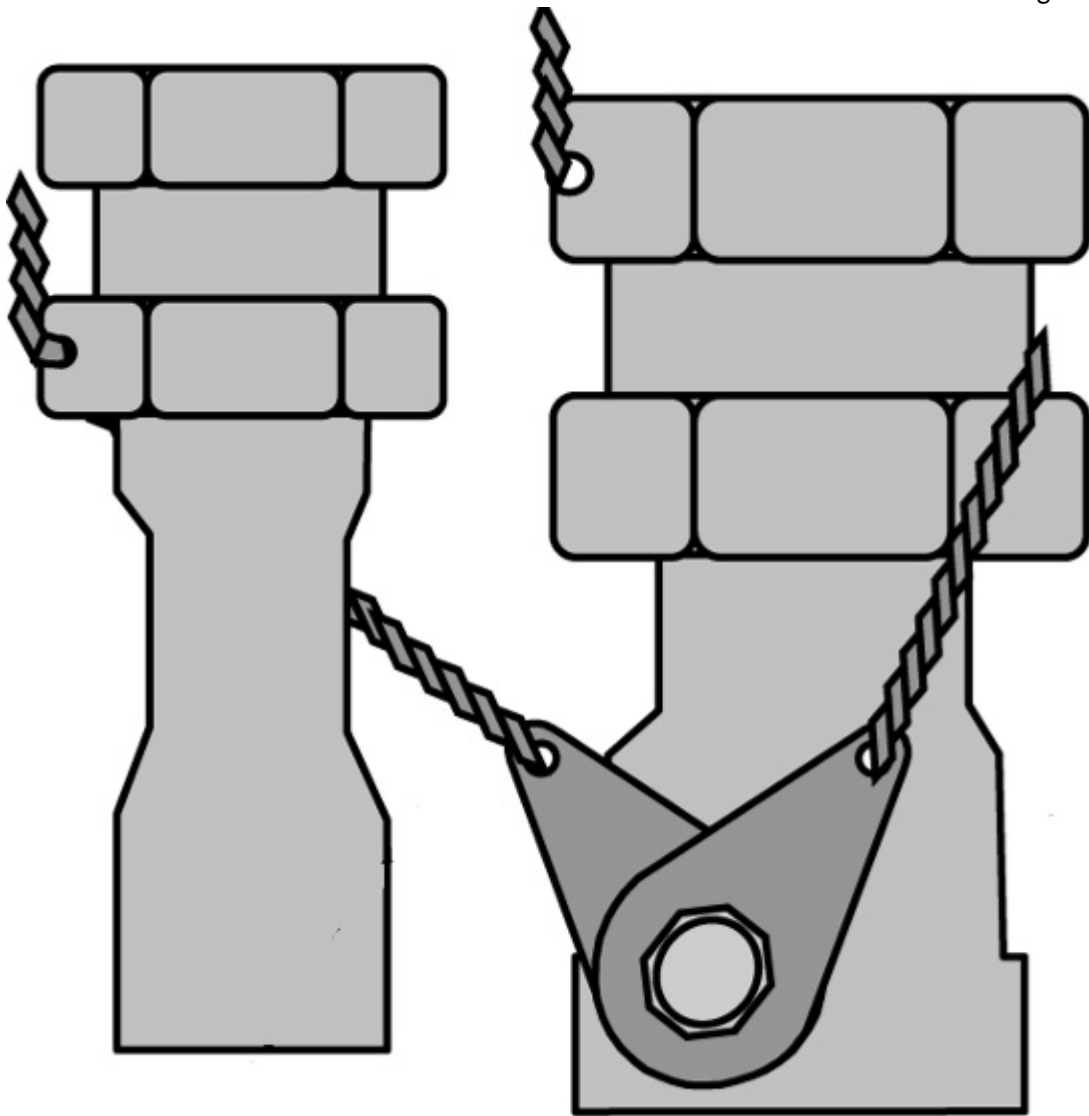

c.

44. The angle of approach of lock-wire should....

- a. not be less than 45 degrees
- b. be less than 35 degrees
- c. be less than 45 degrees

45. Which figure shows an AD nail?

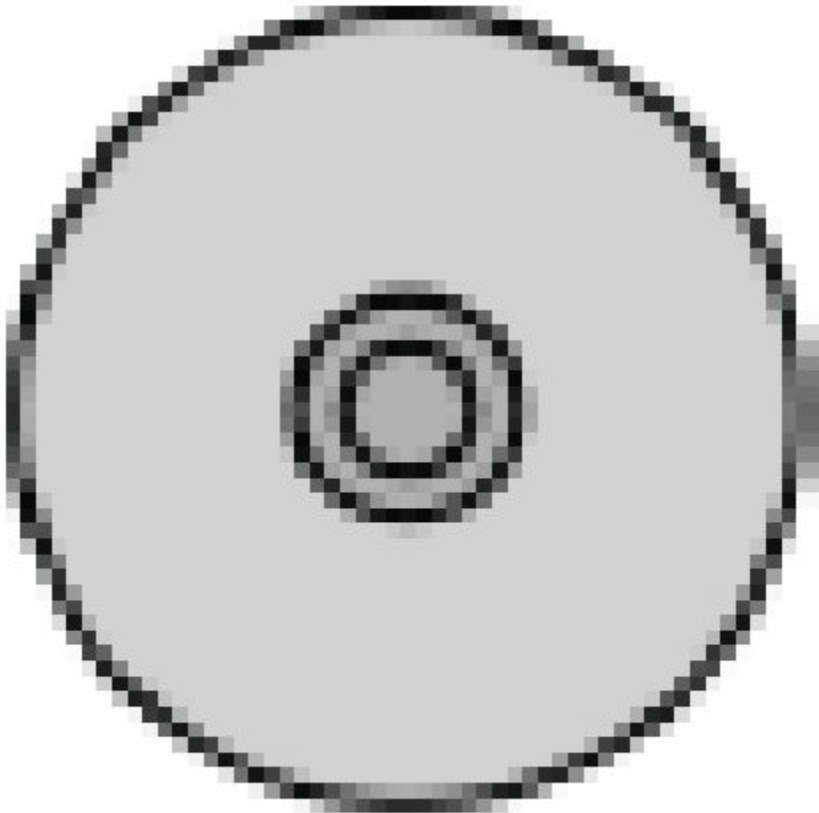

a.

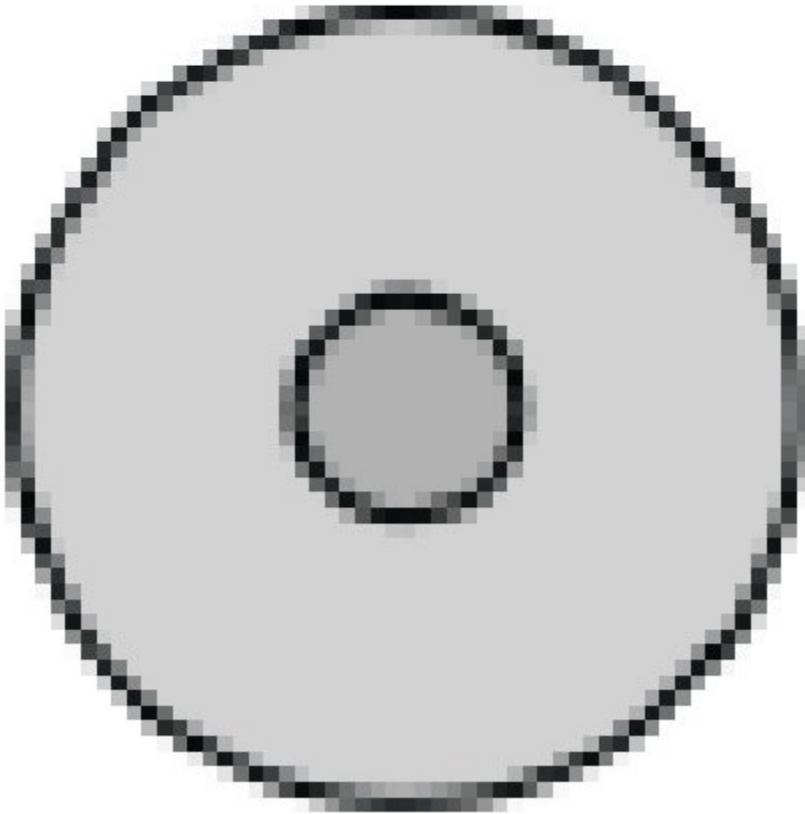

b.

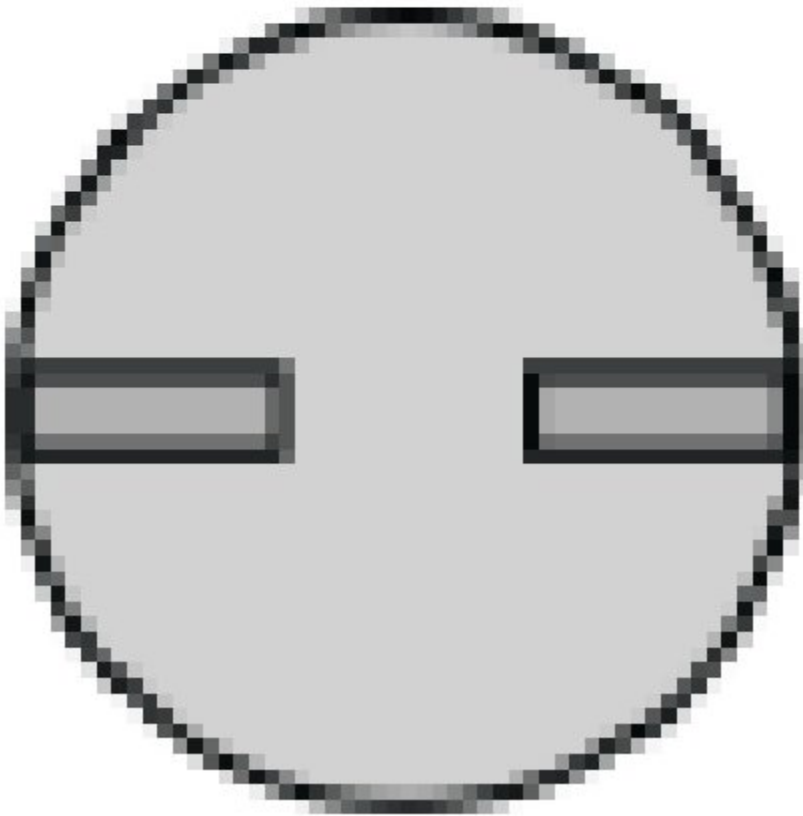

c.

46. Monel (M) rivets are used for riveting....

- a. only copper.
- b. nickel-steel alloys.
- c. magnesium alloy.

47. What is the most used angle of a countersunk rivet?

- a. 100°
- b. 78°
- c. 120°

48. Fuel lines colour code identification is....

- a. red.
- b. green.
- c. yellow.

49. Low pressure hoses are used in....

- a. flexible pipes.
- b. vacuum systems.
- c. hydraulic systems.

50. Replacement fluid lines must be of the same....

- a. size and material as the original line.
- b. size as the original line.
- c. material as the original line.

51. Quick release couplings of hydraulic lines have....

- a. sealant / poppet valves to prevent loss of fluid.
- b. no poppet valves.
- c. no sealant valves.

52. Where are flared-tube fittings made of?

- a. A magnesium alloy.
- b. An iron alloy.
- c. A steel or copper based alloy.

53. What is the Leaf or Carriage spring?

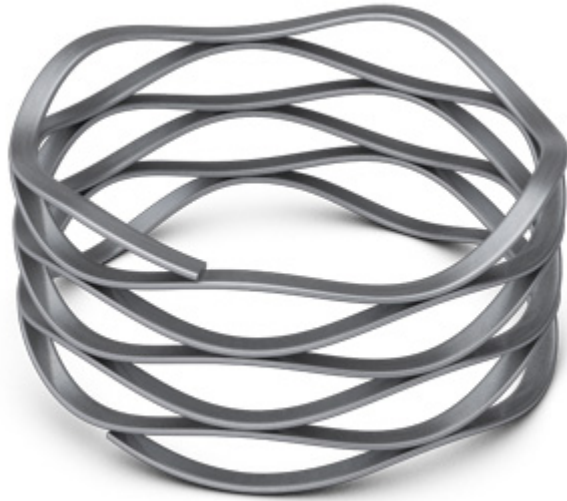

a.

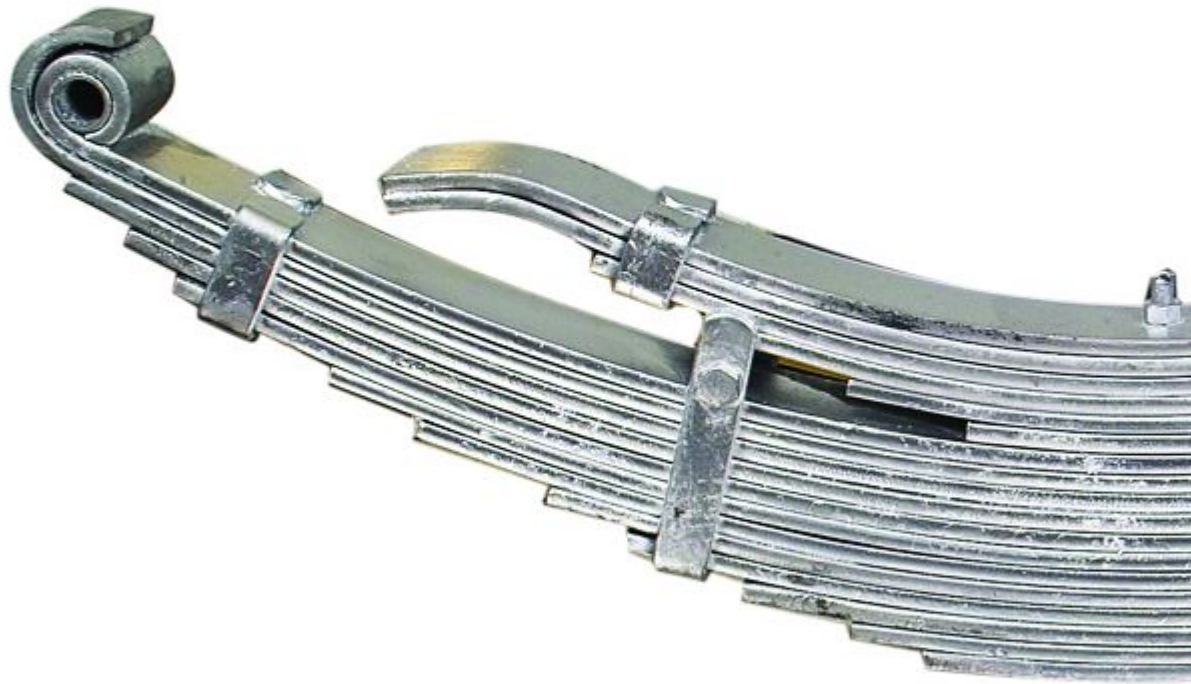

b.

5031242919525075
Module 06 Cat B1.1 2451
According TNA cat B1.1 rev 07A
601654Migrator



54. How is the wire of a tension spring wound?

- a. Close wounded.
- b. Open wounded.
- c. Torsion wounded.

55. How can a needle roller bearing be loaded?

- a. Axially.
- b. Radially.
- c. Axially and radially.

56. Which bearings are better able to cope with heavy loads?

- a. Roller bearings.
- b. Ball bearings.
- c. Large ball bearings.

57. Which bearings are ideal for high rotational speeds?

- a. Bearings which do not have a cage to support the rollers
- b. Ball and Roller bearings
- c. Plain bearings

58. When comparing a roller bearing to a plain (slide) bearing, the roller bearing

- a. has more cooling problems.
- b. has lower friction when starting.
- c. is heavier.

59. Gears are named according to their....

- a. size and shape of their driving source.
- b. purpose; example drive gear.
- c. angle of intersection of the axis and the shape of their teeth.

60. When is a worm gear used?

- a. In places with a lot of space.
- b. When a high reduction in speed is used.
- c. When the axels run parallel to each other.

- 61.** What is a principle function of gears?
- Change the direction of shaft output.
 - Change the speed of rotation and/or their direction.
 - Change the speed of rotation only.
- 62.** Which flight controls are operated with chain and sprockets?
- Main Landing Gear extension
 - Aileron trim
 - Flap screw drives
- 63.** Pulleys in aircraft control systems are usually made from....
- high strength aluminium alloys.
 - resin impregnated fibres.
 - 0 steel alloys with round holes to reduce weight as much as possible.
- 64.** What is usually fitted to both ends of a cable control system and can be adjusted?
- Woven splices.
 - Flared end fittings.
 - Control stops.
- 65.** Control cables that run for long distances inside an aircraft, will need to change direction to allow for complicated structure. The usual method used to change direction are better known as?
- Frames
 - Guides
 - Pulleys
- 66.** The Bowden system of control consists of....
- a stainless steel wire, housed in a flexible sleeve or conduit.
 - non-flex cable system.
 - stainless steel cable used direct spans and with only push function ability.

67. Which colour code is depicted in the figure?

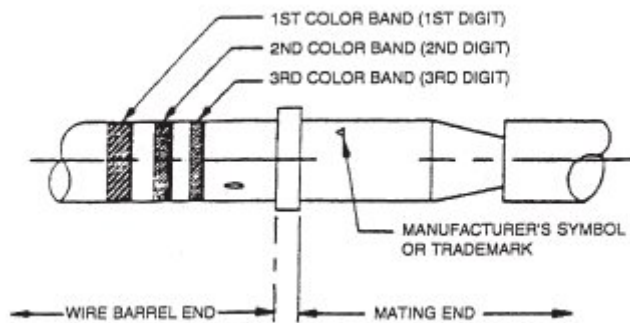

- a. BIN colour code
- b. AWG colour code.
- c. BSW colour code.

68. What type of conductor cable is "a single insulated conductor with a metallic braided outer conductor shield"?

- a. Coaxial cable.
- b. High tension type of cable.
- c. Insulated wire.

69. What are two principal components of a typical crimp termination?

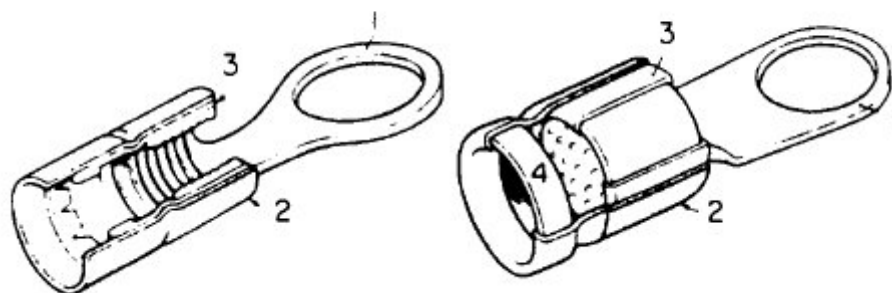

- a. Shell and plug.
- b. Socket and shell.
- c. Crimping barrel and tongue.

70. What is the purpose of the barrel in crimped terminals?

The barrel is designed to....

- a. contain the wire bundle.
- b. support the cable conductor do to vibration effect.
- c. fit closely around the cable conductor so that after pressure has been applied a large number of contact points are made.

71. How can you detect the difference between front or rear release connectors?

- a. Insulator of a front release is made of hard material.
- b. Insulator of a front release is made of soft material.
- c. Insulator of a rear release is made of soft material.

72. Explain the identification of the connector part number: MS24266 G 22 T 55p.

- a. Titanium conductive connector with 22 connector pins and a bayonet coupling type.
- b. Stainless steel non-conductive connector, shell size 22 and threaded coupling type.
- c. Aluminium conductive connector, shell size and threaded coupling type.